

FISCHER

& ASSOCIATES
REAL ESTATE



HOTEL NASHVILLE

In Historic Brown County, Indiana

\$1.8 million

Full Service Restaurant & Kitchen | Bar with 3-way License

Indoor Pool | Spa | Sauna

Outdoor Pavilion and Deck Area Perfect for Parties & Weddings

Room amenities include refrigerator, sink, microwave, coffee maker...

4 Buildings -3 Stories -46 Rooms

Suites have separate bedrooms.

All rooms have exterior access and balconies/decks.

2.18 Acres of Prime Downtown Nashville Real Estate!

Call Fischer in Fishers!

12350 Bellingham Boulevard
Fishers, IN 46037

DIRECT: 317.250.7364
FAX: 317.485.7164

l.fischer@att.net
www..FischerandAssociates.biz



Lynn S. Fischer - Broker/Owner
Fischer & Associates, Inc.

Historic Brown County/Nashville, IN



For more than 100 years, artists and adventurers alike have been drawn to the rustic beauty and quiet charm of Brown County, one of America's original artists' colonies. Everyone finds something to love, whether it's eclectic boutiques and galleries, mountain biking and zip line adventures, outstanding scenery, welcoming accommodations or simply the opportunity to reconnect with one another. Snuggled into the hazy, blue hills of Southern Indiana, Brown County celebrates a rich history every day, with many shops and restaurants residing in

historic homes and buildings. There are two covered bridges in the area dating back to the 1800s, a Pioneer Village and establishments that help tell the story of how Brown County became known as the "Art Colony of the Midwest" with a unique tourist town sprouting up around it.

Year round activities in Nashville, Indiana, and surrounding Brown County, center around hiking, biking, shopping and antiquing. The quaint village of Nashville is a great place for a romantic getaway, with hundreds of unique craft, specialty and antique shops, and great music and theatre venues.



Getting married in Brown County Indiana has become "The thing to do!" Just like Gatlinburg and Las Vegas, Brown County Indiana has wedding chapels, outdoor gazebos, bed and breakfasts, quaint hotels and private, romantic cabins.

For more information on the Brown County/Nashville area, visit browncounty.com or nashville-indiana.com.

Hotel Nashville



Towering impressively above the village of Nashville, overlooking the beautiful hills of Brown County in southern Indiana, sits the Hotel Nashville. A Brown County mainstay since 1989 with easy access to downtown shopping and artisan masterpieces, Hotel Nashville consists mainly of one bedroom suites, with various square footage designs and make-ups for individual tastes and styles.

Hotel Nashville guests are treated to a rich array of luxurious amenities – whirlpool suites, mini-suites, and hot tub rooms are all available at reasonable rates.

Guests can enjoy a heated indoor pool, sauna and whirlpool spa, and the opportunity to quietly bask in the sun on the spacious adjacent deck.

The hotel kitchen creates a wide variety of dinner entrées and special menus for its guests. Hotel Nashville's intimate dining room seats up to 55 people and can service all of your special social gatherings such as weddings, anniversaries, family reunions and tail-gait parties. If you've enjoyed what you've eaten while dining at Hotel Nashville, they also offer full array of menu items to satisfy those special catering needs.

Indoor Guest Amenities



Large Indoor Pool.

Private Sauna Area

Separate Jacuzzi Spa



Outdoor Property/Stunning Vistas



Registration Desk & Offices, Meeting/Breakfast



Extra Commercial Lot & Parking



*Suite decks with top of the hill views of
Beautiful Downtown Nashville, TN*



*Lobby & Fireplace Music Room, Coffee Bar,
Upstairs Dining Room, Overlook/Bar & Seating*

Bar Area & Overlook



Inside Bar and Table seating plus Romantic Overlook Area seating

Dining Room & Catering Kitchen



Formal Dining & Breakfast Bar Area



One Bedroom Suite Style



*Walk in
Showers
Or
Tub Showers*



Property Layout

HOTEL NASHVILLE

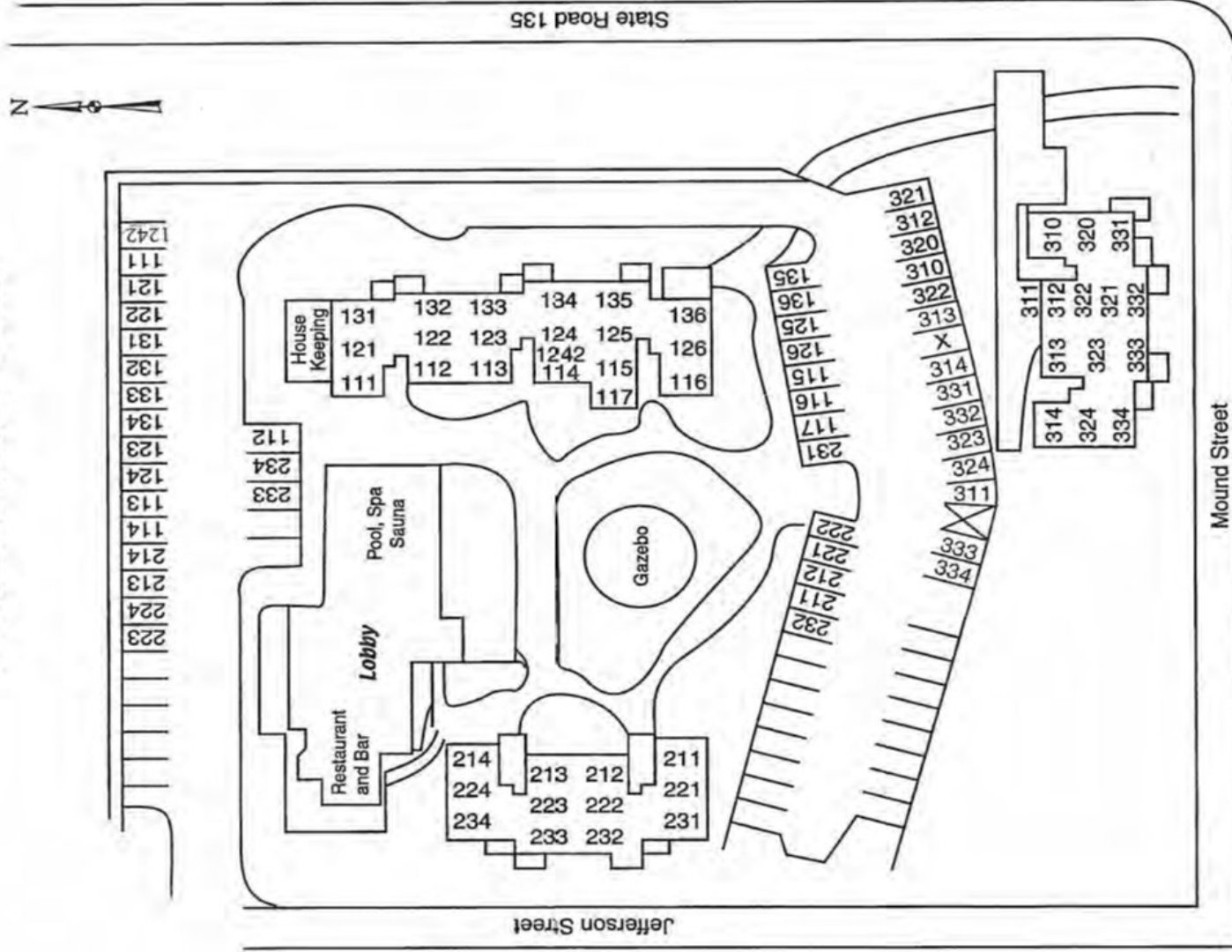

Property Aerial View



Building Layouts

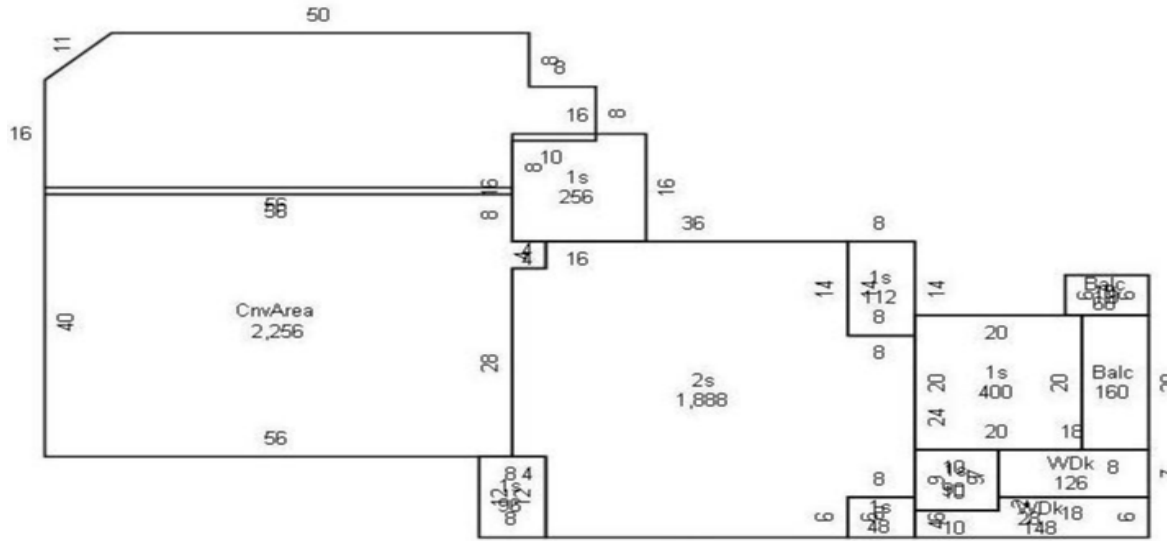

LOBBY, POOL, SPA,
 KITCHEN, DINING AREA
 LEFT

BUILDING #1
 BELOW

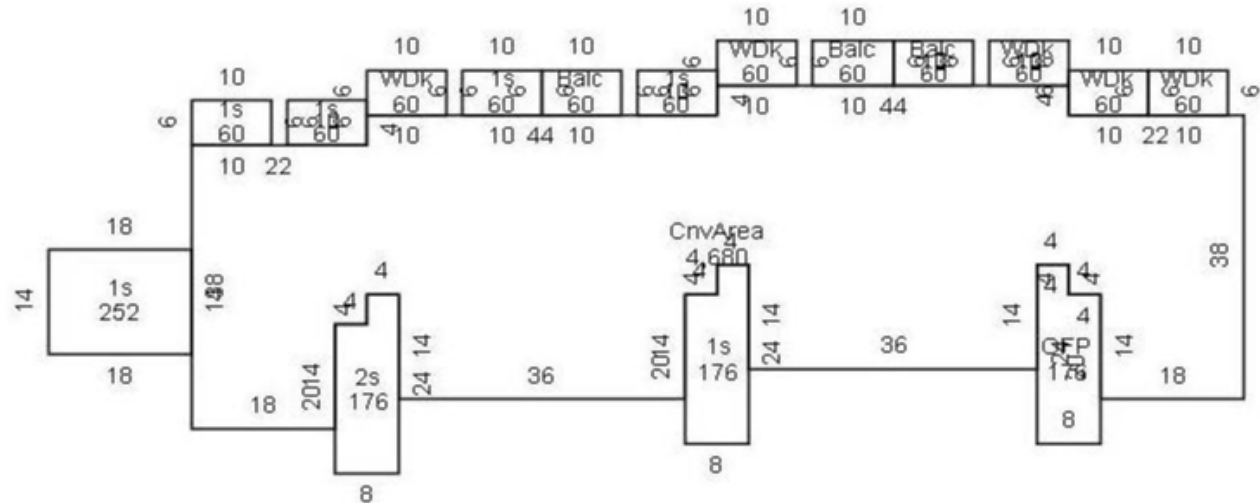

Building Layouts

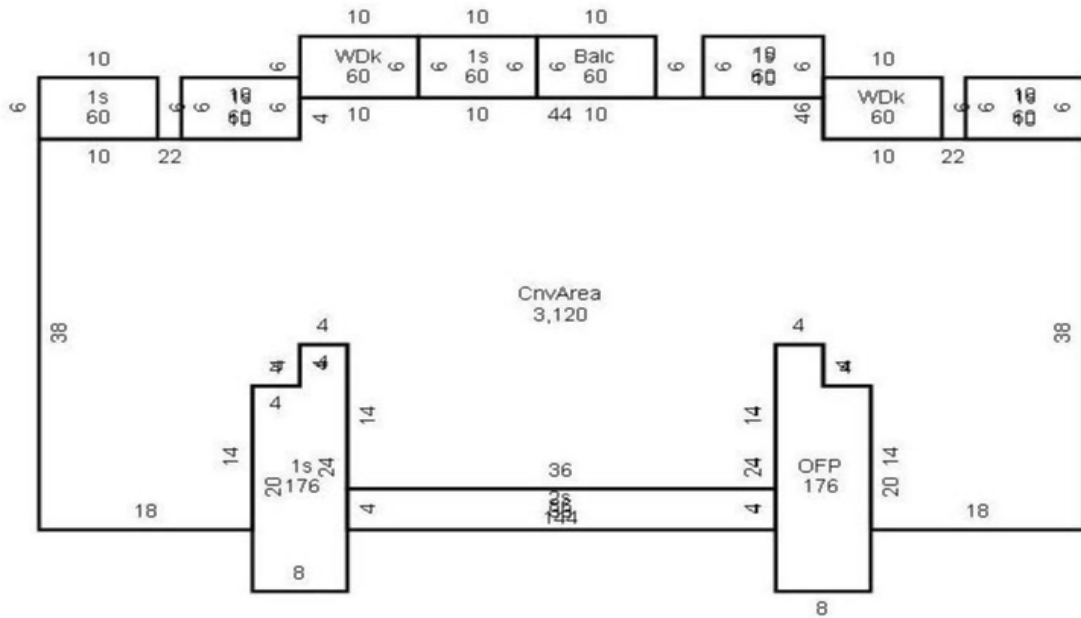

BUILDING #2
LEFT

BUILDING #3
BELOW

